

REVISION HISTORY			
REV.	DESCRIPTION	DATE	DRAWN BY
1	ORIGINAL PRINT	11/29/2016	N. LAWRENCE
2	UPDATED TO AMDS-1	6/21/2022	T. JORGENSEN

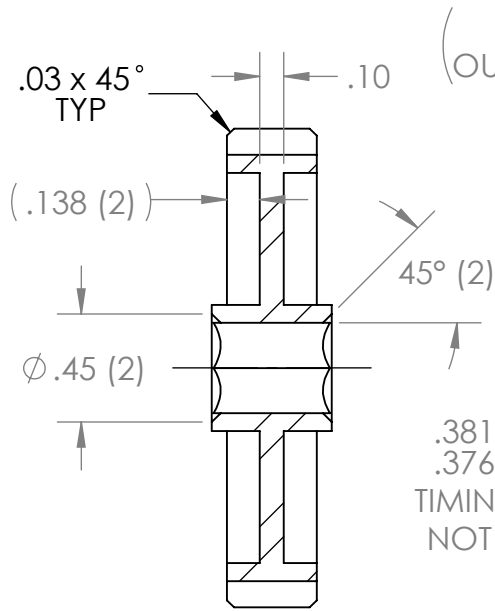

SECTION A-A

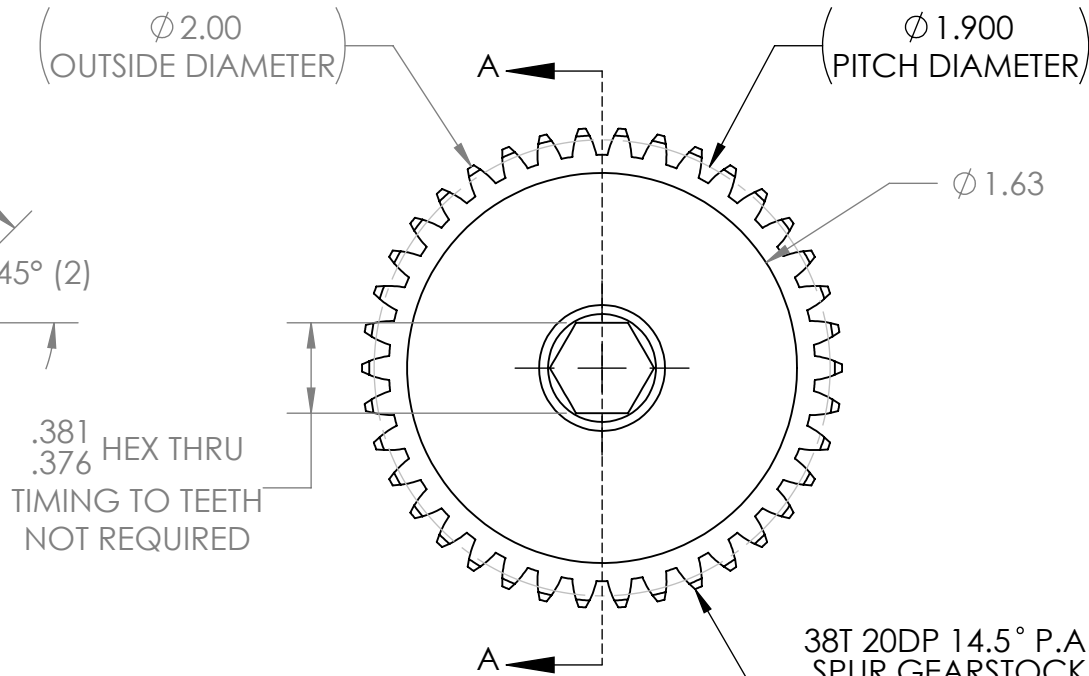

38T 20DP 14.5° P.A.
SPUR GEARSTOCK
CLEAN CUT
NO BURRS BETWEEN TEETH

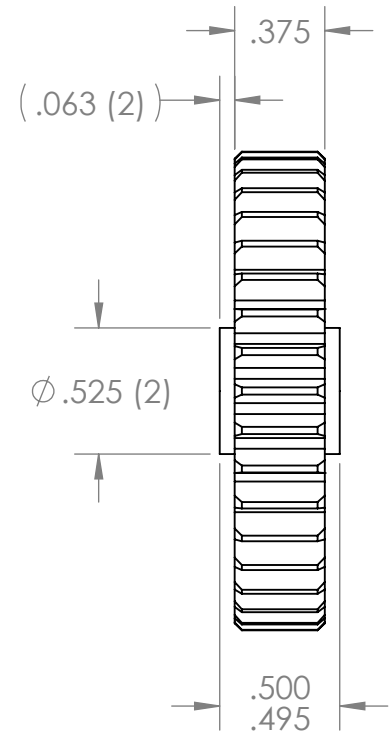

*** SEE CAD FOR ADDITIONAL TOOLPATH INFO***

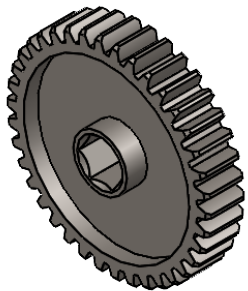

UNLESS OTHERWISE SPECIFIED:		COMMENTS:					
DIMENSIONS ARE IN INCHES		DUAL DIMENSIONS ARE IN MILLIMETERS.					TITLE:
TOLERANCES: FRACTIONAL ±1/16 ANGULAR: MACH ±1° ANGULAR: BEND ±5° ONE PLACE DECIMAL ±0.1 TWO PLACE DECIMAL ±0.01 THREE PLACE DECIMAL ±0.005 FOUR PLACE DECIMAL ±0.0005		BREAK ALL SHARP EDGES.		38T 20DP 14.5PA 0.375IN HEX BORE GEAR			
MATERIAL 4140 STEEL		CHECKED	NAME NL	DATE	SIZE	DWG. NO.	REV
FINISH DEBURRED ZINC PLATED		ENG APPR.		9/13/22	A	am-3538	2
DO NOT SCALE DRAWING		MFG APPR.			SCALE: 1.25:1 SHEET 1 OF 1		
		Q.A.					